

X E R O S  
X E R O S

# The Future of Laundry



# WHAT WE DO

Xeros licenses sustainable proprietary technology solutions for the laundry and apparel industries.

These drive significant cost, energy and water efficiencies, reducing pollution, in both the manufacture and laundering of clothing.



# INDUSTRY PROBLEMS

## THE ENVIRONMENTAL COST OF FASHION

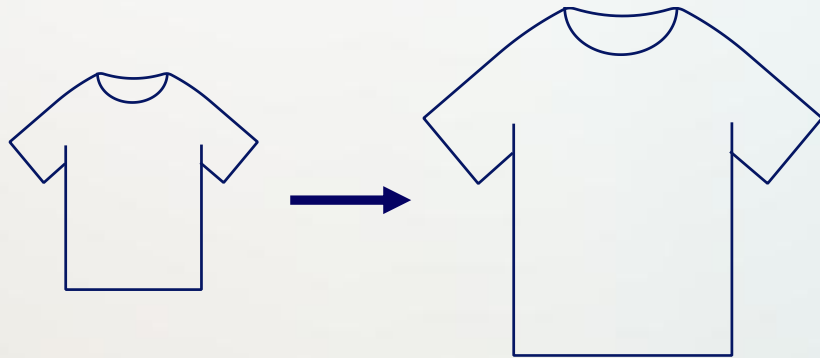

We are buying **60% more clothes** than 25 years ago, with most ending up in landfill at end of life.<sup>1</sup>

The fashion Industry is under **pressure from consumers, legislation and regulation**, but solutions for manufacture are non-existent and initiatives on raw material production invariably come at a higher price.

## LACK OF LAUNDRY INNOVATION

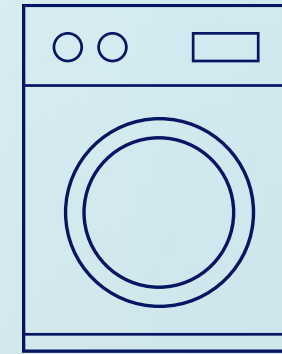

The washing machine industry is unable to **break the link** between **clean clothes and garment damage**

The appliances industry is under continual pressure to improve efficiency of water, detergent & energy usage BUT **a lack of true innovation** has been unable to affect a step change.

# THE SOLUTION

THE POWER OF XORBS

By introducing a new element to the Laundry wash process we have created...

## 'The Future of Laundry'

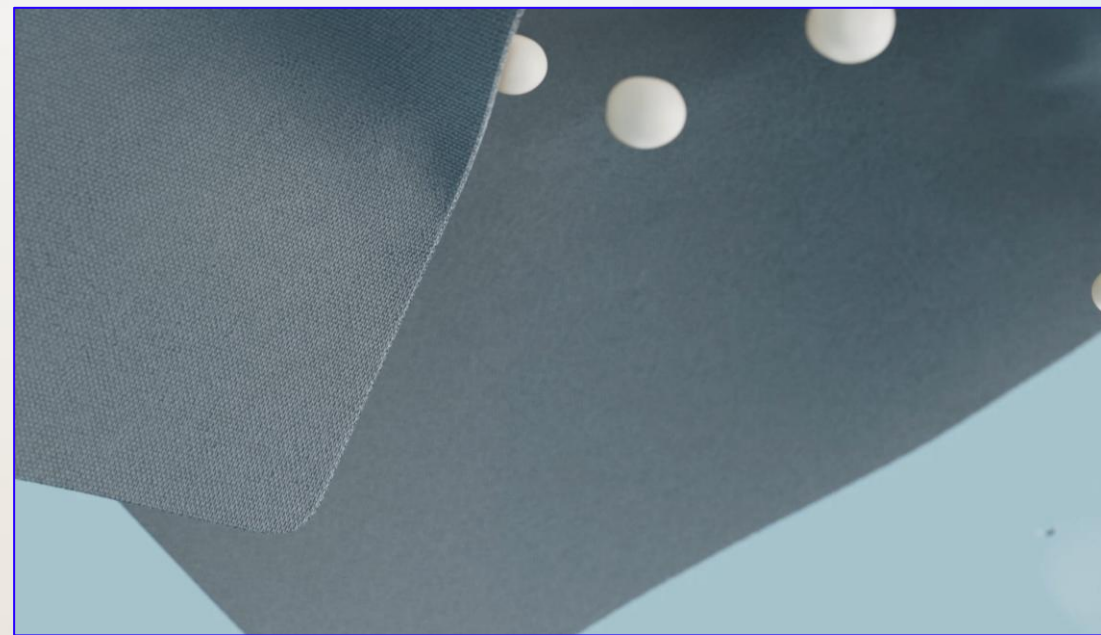

XOrbs, our patented reusable polymer spheres, gently increase mechanical action, improve chemical efficiency, wash performance and **protect clothing** from harsh fabric on fabric contact.



**100%**  
IMPROVEMENT IN  
GARMENT LIFE



UP TO  
**80%**  
LESS WATER



UP TO  
**50%**  
LESS ENERGY



UP TO  
**50%**  
LESS CHEMISTRY

# THE SOLUTION

THE POWER OF FILTRATION

By introducing innovative microfibre filtration technology we have created...

## 'The Future of Laundry'



**XFilter** is our market leading washing machine **microfibre capture device**.  
Highest independently verified capture rate that works with any domestic washing machine.  
**No replacement cartidges** are needed and it **lasts for the lifetime of machine**.  
Available as an accessory (as left) or integrated during manufacture (as right).

# MULTIPLE APPLICATIONS

SIGNIFICANT INDUSTRIES IN PLAY

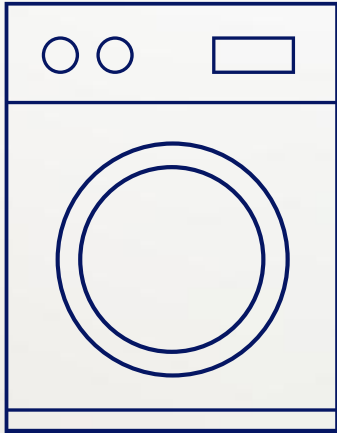

Domestic Laundry  
**Approx. market size**  
**\$63bn**

Washing machines for use in home

Circa 99% of front loader production are from  
10 x Global brand groups

Under energy & water reduction pressure  
Seeking 'Fabric Care' solutions

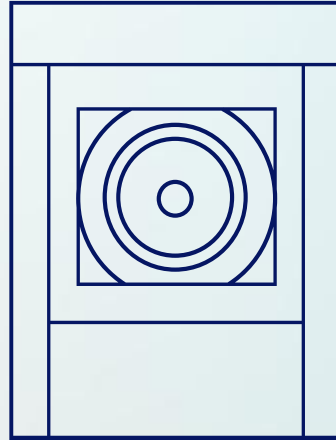

Commercial Laundry  
**Approx. market size**  
**\$7.3bn**

Washing machines for use in hospitality,  
leisure, healthcare, etc.

6 x key machinery providers  
Seeking 'Water reduction' solutions

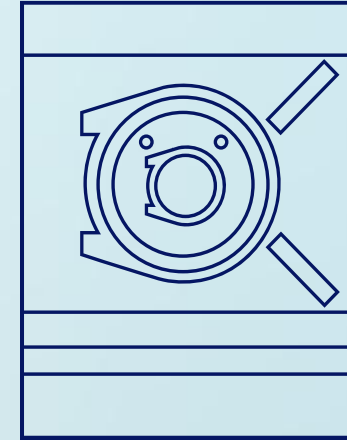

Garment Manufacture  
**Approx. market size**  
**\$4.1bn**

Final stage 'wash' for all garment manufacture

Fashion industry under significant ESG  
reporting pressure

Limited 'machinery' solutions in response,  
industry reliant on pumice for denim abrasion

# SIGNIFICANT COMMERCIAL PROGRESSION IN 2025



## 1 Product Launch Agreement

**Global Washing Machine Group**  
(Group Sales : c. 7 Million Units p.a.)

Milestone based, time-bound and 'paid for' agreement

Anticipated to launch Xeros technology enabled washing machines in 12-18 months

## 2 Tech Verification

**3 more of the World's Top Ten Washing Machine Groups**  
(Group Sales combined : c. 20 Million Units+ p.a.)

Further Product Launch agreements anticipated within coming months

## 3 Russell Hobbs - Brand Partnership

Microfibre Filter expected to be launched within 2025

## 4 Launch indications on XF<sup>3</sup>

Microfibre Filter to be launched subject to final testing with...  
Major European Washing Machine retailer and Global Washing Machine Brand  
(Combined Sales 27+ Million Units p.a.)

## 5 Agreement to Develop

Integrated Microfibre filtration capability with fast growing washing machine manufacturer

Access into Global washing machine supply chain in anticipation of Legislation mandating inclusion

## 6 Leading Global Denim Manufacturer and Brand Group partnership(s)

Purchase orders in place for machine placements at 'Ambition Apparel'  
(Group Sales approx. 9 million units p.a.)

Final onsite trials completed at Major Manufacturing & 'Branded Denim' Group  
Plans to roll out to manufacturing facilities across Turkey and Egypt  
(Group Sales approx. 20 million units p.a.)

Further manufacturer placements anticipated within coming months



# XC LAUNDRY CARE

FABRIC CARE TECHNOLOGY

# DOMESTIC LAUNDRY

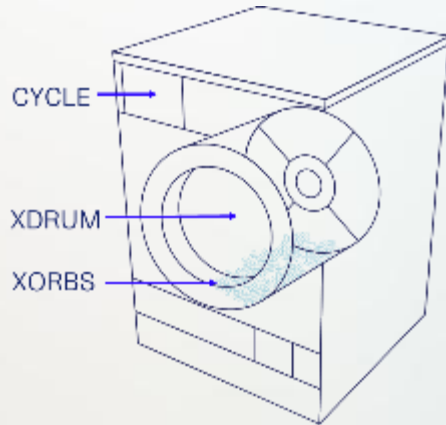

Hybrid operation; i.e.  
additional feature  
to core cycles



Elongates  
lifespan  
of clothes

Global opportunity – **c. 100 million units + p.a.**  
Global production concentrated in 10 OEMs

**\$25 p.u.**  
Xeros revenue  
Royalty & XOrbs

**100%**  
Clothing lifespan  
extension

**11**  
Live patent  
coverage



# DOMESTIC LAUNDRY

COMMERCIAL MOMENTUM



## Product Launch Agreement with leading Global Washing Machine Group

Agreement reached for a paid 12-18-month development process to enable the brand Group to launch a fully XOrb enabled washing machine.

Provides Xeros access to c. **7 million units per annum**

Advanced discussions underway with **3 further global OEMs** for a similar '12 month to production' paid for development programme.

Further news flow anticipated within coming months.

Would provide access to a further 20 million units per annum.

Live partnership with largest Domestic Laundry manufacturer in India





# COMMERCIAL LAUNDRY



**80%**  
LESS WATER

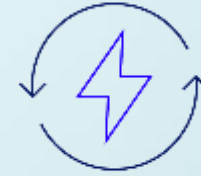

**50%**  
LESS ENERGY



**50%**  
LESS CHEMISTRY

Global opportunity - **c1.5 million units per annum**

**c. \$20k**  
**p.u.**  
Xeros Rev  
Royalty & XOrbs

**20%+**  
Uniform life  
extension

**13**  
Live patent  
coverage

# COMMERCIAL LAUNDRY

PLANNED GROWTH

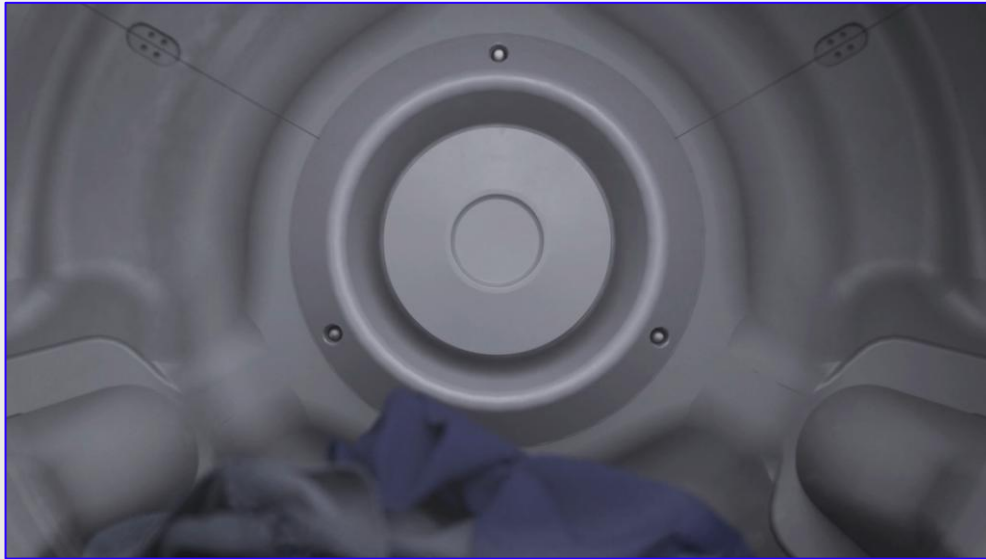

## LIVE IN HOSPITALITY & WORKWEAR MARKETS

Uniforms being laundered with Xeros XOrb technology for  
**Air France, EDF, SNCF and Renault.**

Also now being used in Firefighting Industry

Machines currently installed at  
Marriott, Taj, ITC, St. Regis and Fairfield Hotel chains

Planned growth & focus in 2026

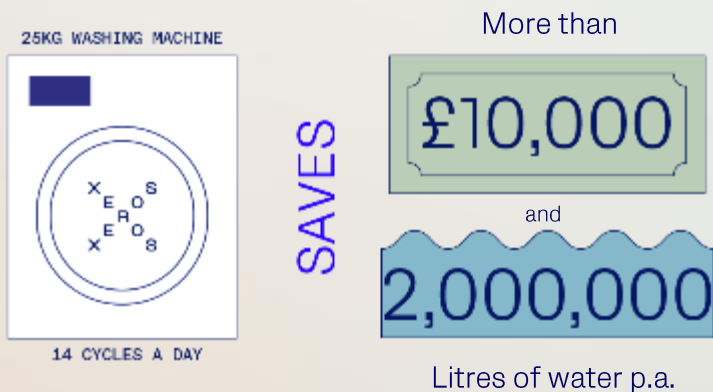

A close-up photograph of blue denim fabric, showing the texture and stitching. A white rectangular frame is centered on the image, containing text.

# XFN GARMENT FINISHING

GARMENT FINISHING TECHNOLOGY

# GARMENT FINISHING



**100%**  
LESS PUMICE



UP TO  
**100%**  
LESS WATER\*



UP TO  
**25%**  
LESS CHEMISTRY



UP TO  
**30%**  
CO2e SAVING

Global opportunity – **4,000 units per annum**

Xeros lifetime revenue  
**\$50k p.u.**  
Royalty & XOrbs

Up to  
**20%**  
Cost savings

**11**  
Live patent coverage

\*XOrbs allow some steps of the denim production process to be performed waterlessly



# GARMENT FINISHING

COMMERCIAL MOMENTUM

LIVE IN MARKET WITH INDUSTRY LEADER

Global Denim manufacturing partnership in place..!

Machine placements agreed with 'Ambition Apparel', one of Pakistan's leading denim manufacturers (c. 9 million units p.a.) to implement Xeros XOrb technology.

XOrb-enabled machines concluded successful on-site trials with significant branded denim & manufacturing groups (c. 20 million units p.a.)

Anticipation of roll out to full global manufacturing facilities.

Significant cost and CO2e benefits being proved at scale at manufacturing sites.



# XF MICROFIBRE FILTRATION

MICROFIBRE FILTRATION TECHNOLOGY

# MICROFIBRE FILTRATION

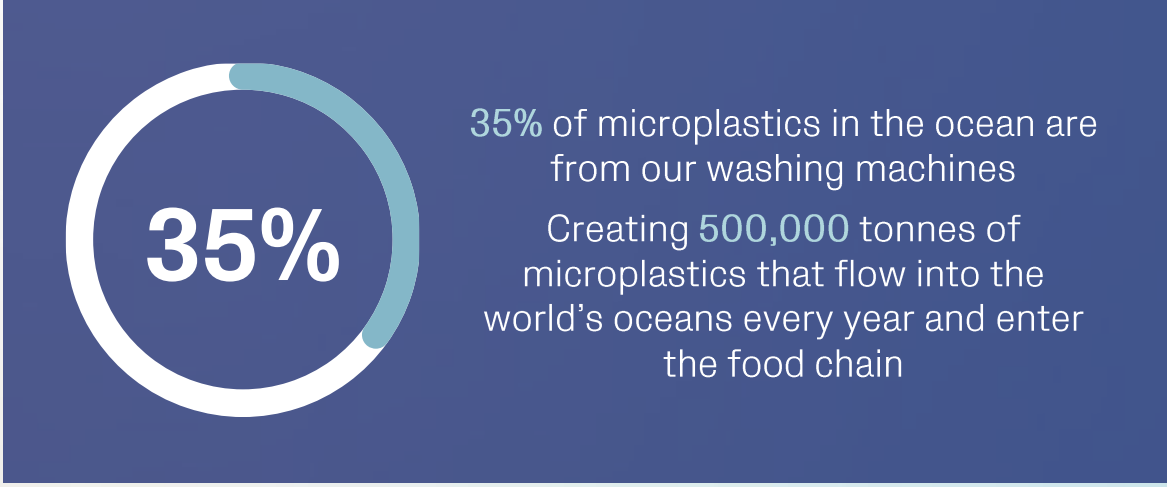

Xeros is seeding the market and establishing partnerships with its external device in anticipation of the legislated mandatory inclusion of integrated devices in domestic washing machines

Xeros Rev  
**\$3-\$8**  
per unit

Up to  
**99%**  
Capture rate

**9**  
Live patent coverage



# MICROFIBRE FILTRATION

COMMERCIAL MOMENTUM

## Russell Hobbs and XEROS

Co-Branded device to be on sale in 2025

Launch indications agreed with:-

- Europe's largest electronics retailer
- Global Washing Machine Brand

Provides access to **c. 27 million+** units per annum

## Agreement to develop integrated filter

Letter of Intent to develop an integrated device with Weili Foshan one of China's leading washing machine manufacturers.

Provides access to Global washing machine supply chain in anticipation of Legislation mandating inclusion

Further fruit from Xinbao Donlim Strategic agreement.



# COMMERCIAL ROADMAP

THE FUTURE OF LAUNDRY

# COMMERCIAL ROADMAP

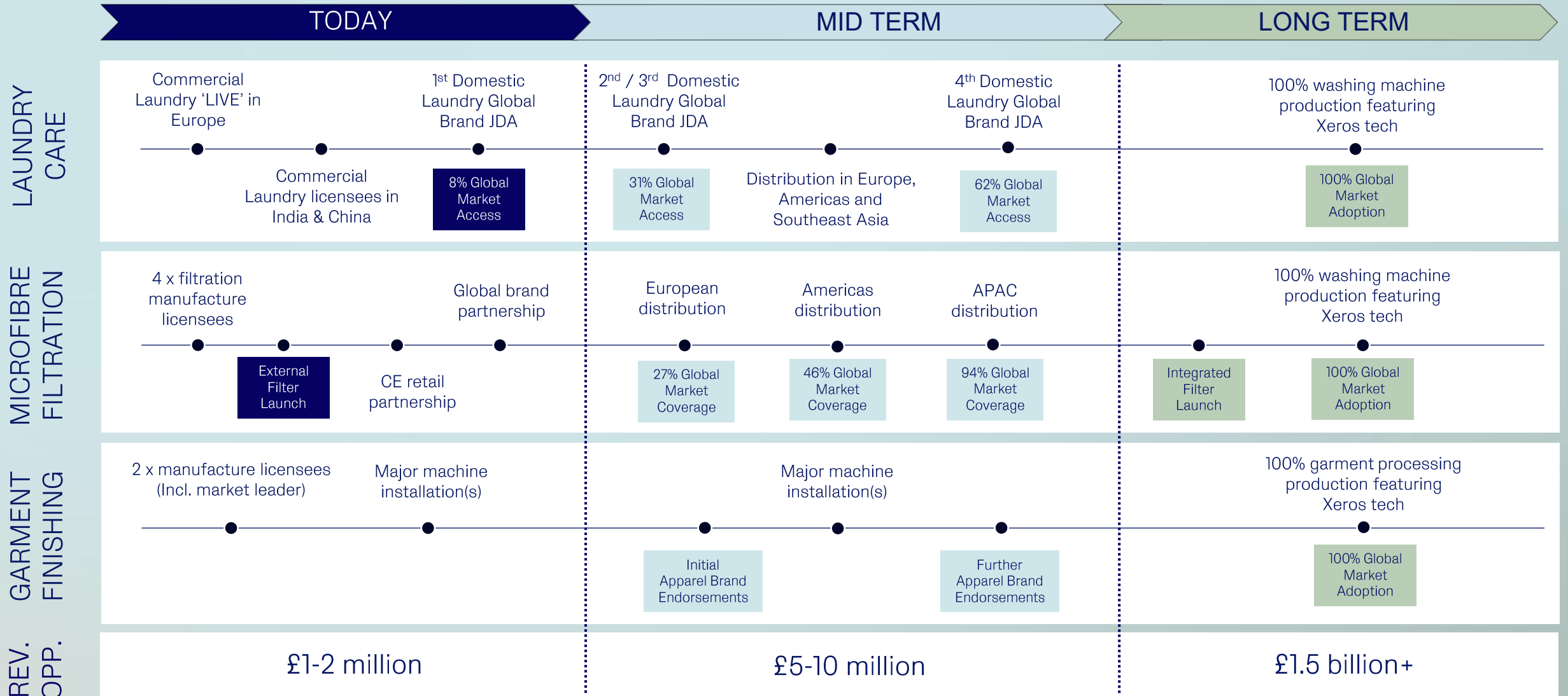

# FINANCIALS

THE FUTURE OF LAUNDRY

# PROFIT AND LOSS

# CASHFLOW STATEMENT

## PROFIT AND LOSS

H1 2025

REVENUE	65
COST OF SALES	(18)
GROSS PROFIT	47
ADMINISTRATIVE EXPENSES	(1,797)
ADJUSTED EBITDA	(1,627)
SHARE BASED PAYMENT EXPENSE	(54)
DEPRECIATION OF TANGIBLE FIXED ASSETS	(69)
OPERATING LOSS	(1,750)
NET FINANCE INCOME	23
LOSS BEFORE TAXATION	(1,727)
TAXATION	-
LOSS AFTER TAX	(1,727)
LOSS PER SHARE (P)	(0.33)

## CASHFLOW AND FINANCING

H1 2024

LOSS BEFORE TAX	(1,727)
ADJUSTMENT FOR NON-CASH ITEMS	
DEPRECIATION OF TANGIBLE FIXED ASSETS	69
SHARE BASED PAYMENT	54
INCREASE IN INVENTORIES	(2)
DECREASE IN TRADE AND OTHER RECEIVABLES	91
DECREASE IN TRADE AND OTHER PAYABLES	(48)
FINANCE INCOME	(38)
FINANCE EXPENSE	16
CASH USED IN OPERATIONS	(1,584)
TAX	-
NET CASH OUTFLOW FROM OPERATIONS	(1,584)

# CASHFLOW STATEMENT

## CASHFLOW AND FINANCING

H1 24

### INVESTING ACTIVITIES

FINANCE INCOME

38

FINANCE EXPENSE

(16)

PURCHASE OF PROPERTY, PLANT + EQUIPMENT

-

CASH PLACED ON/(REMOVED FROM) DEPOSIT

-

NET CASH INFLOW/(OUTFLOW) FROM INVESTING ACTIVITIES

22

### FINANCING ACTIVITIES

PROCEEDS FROM ISSUE OF SHARE CAPITAL, NET OF COSTS

12

PAYMENT OF LEASE LIABILITIES

(44)

NET CASH INFLOW FROM INVESTING ACTIVITIES

(36)

INCREASE/(DECREASE) IN CASH AND CASH EQUIVALENTS

(1,594)

CASH AND CASH EQUIVALENTS AT START OF PERIOD

2,803

EFFECT OF EXCHANGE RATE FLUCTUATION ON CASH HELD

-

CASH AND CASH EQUIVALENTS AT END OF PERIOD

1,209

# SHARE REGISTER

## FUND

## % VOTING RIGHTS

Maven Capital

12.78

Dowgate Capital

12.63

Lombard Odier

7.77

Entrepreneurs Fund

6.86

Rathbones

6.41

Interactive Investor

5.75

Hargreaves Lansdown

5.34

Spreadex

3.65

# SUMMARY



Market ready, commercial agreements in place, launching 2025



Market leading technology built by experts in the field

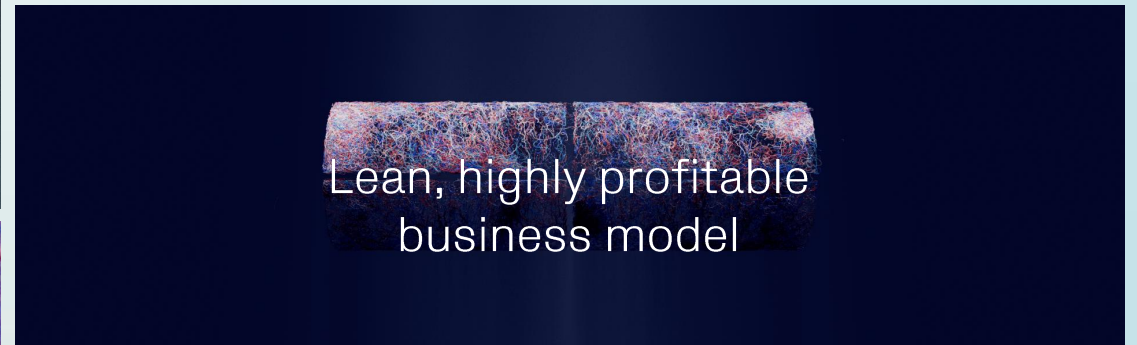

Lean, highly profitable business model



Global market growth driven by environmental initiatives and new legislation



Significant IP, in 38 patent families

X  
E  
R  
O  
S  
X  
E  
R  
O  
S

## The Future of Laundry

